

Expect the best. **REFRA**TECHNIK

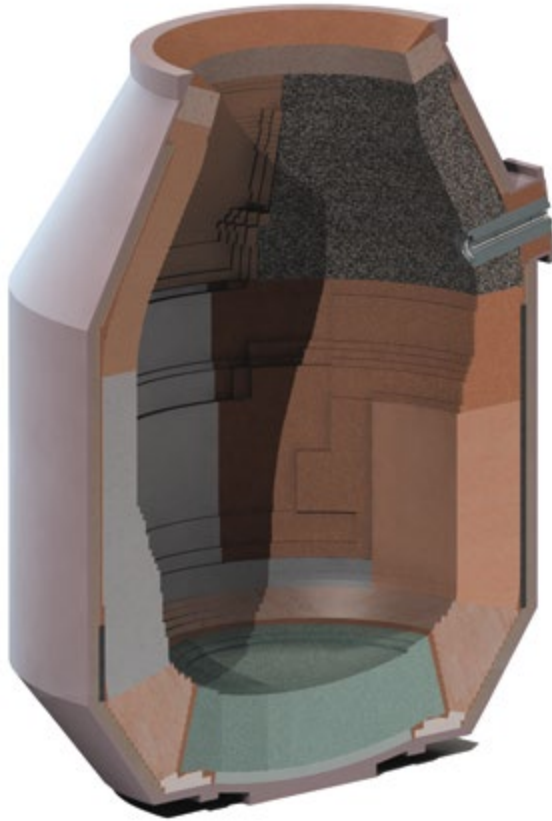

Lining Installation Manual Volume 1 – BOFs

REFRA
ACA
DEMY
GROUP WORLDWIDE



Lining Installation Manual

Volume 1 – BOFs

Preface

Professional installation of refractory materials is a decisive parameter in the refractory concept. Thanks to the many years of experience acquired by Refratechnik service supervisors at home and abroad, the accumulated know-how about possibilities and feasibilities in all areas of refractory linings, it is now possible to implement extremely complex refractory concepts. This compendium is intended as a contribution for the professional simplified installation of refractory materials, and the professional handling of difficult situations. Installation instructions plus diagrams and graphic material assist on-site discussions with the customer about any difficulties arising, and help to find professional solutions for a positive result of the refractory concept. Many parts of the compendium are based on the reports and experiences of Günther Schulz, our long-time site supervisor, to whom we owe special thanks.

Publisher:

Refratechnik Steel GmbH

Schiessstrasse 58

40549 Düsseldorf

Germany

Phone +49 211 58580

Fax +49 211 585849

steel@refra.com

www.refra.com

Editor:

Prof. Dr. Ing. habil Helge Jansen

Table of contents

Preface	1
Table of contents	3
Introduction	5
1. Function and description	9
2. Zones and materials	11
2.1. Upper cone and mouth	13
2.2. Tapping area and slag zones	14
2.3. Trunnion area	16
2.4. Lower cone and barrel	18
2.5. Bottom	19
2.6. Scrap impact zone	20
3. Lining practice	21
3.1. BOF brick shapes	21
3.2. Preparations for lining the BOF	24
3.2.1. Permanent lining.	29
3.2.2. Installing the first layer in the BOF	31
3.3. BOF bottom	32
3.3.1. Bottom designs	32
3.3.2. Rammed joint	40
3.3.3. Special case: Full hemispherical bottom	44

3.4.	Oblique installation in upper cone with double-wedge or end arch bricks	51
3.5.	Lining the taphole	57
3.6.	Expansion compensation	63
3.7.	BOF topping versions	67
3.8.	Heating the BOF to operating temperature	74

Introduction

Steel production is a highly complex process that is inconceivable without the use of refractory materials. The following factors can be influenced by the selection and quality of the refractory material, as well as the most suitable design of the refractory lining:

- Quality and analysis of the produced steel type
- Quantity of steel produced per unit of time
- Safety of persons and equipment involved in the production process

Faulty or low-quality refractory materials will hamper the adjustment of analysis values for steel and slag. For example, the dissolution of oxygen from the steel melt is determined by the oxidation potential of the refractory material used.

Similarly, today's demands on steel purity grades would be impossible with the standard rammed sand ladles used several decades ago.

Storage, transport and processing of hundreds of tons of molten metal and slag require maximum reliability and safety of the refractory material. Failure of a refractory lining can lead to fracturing of the vessel, and therefore to a spill of liquid steel. This could damage or even destroy machinery and equipment to such an extent that production is interrupted for weeks or even months.

A smooth reduction-, melting-, and refinement-process without unscheduled downtimes for repair or replacement of the refractory material fits harmoniously into the overall steel production-process. Disturbances in the BOF or ladle operations not only result in an interruption of the material flow for the foundry, but also in a backlog in the delivery of pig iron, which must then be stored temporarily – if at all possible – or even causes the blast furnace to be shut down. Early failure of refractory linings leads to process interruptions during which no steel is produced, and therefore no added value is created.

1. Function and description

Basic Oxygen Furnace (BOF) is the name given to a vessel in which pig iron is converted into steel. By blowing pure oxygen onto or into the molten iron via oxygen lances or nozzles (oxidation), carbon is removed from the hot metal, thereby converting it into raw steel. The size, i.e. the capacity of the BOF, varies from plant to plant. The smallest BOFs accept just 20 tons, whilst the largest can take up to 400 tons of steel. Process cycle time is measured from charging the BOF until discharge of the raw steel. BOFs have a cauldron shape and are lined with refractory material to withstand the high temperatures. In the upper part of the vessel there is an opening (taphole) for discharging of the molten steel. The process oxygen for converting the pig iron into raw steel is usually introduced into the BOF via a central water-cooled lance. In addition, purging plugs must be provided e.g. in the BOF bottom or wall to permit metallurgical work in the BOF.

When the blowing process has been completed, and the heat has reached the required temperature and chemical composition, the BOF is tilted so that the raw steel can be poured into the casting ladle via the taphole. The BOF is then tilted to the opposite side so that the slag can be emptied into a slag ladle through the BOF mouth.

2. Zones and materials

Compared with a steel casting ladle, a BOF is far more complex. Simply the difference in the quantity of refractory materials for ladles (about 20 – 50 tons), and for BOFs (about 100 – 600 tons) involves a far more difficult design, particularly with regard to thermomechanical loads as well as considerably more complex installation work. Furthermore, entirely different demands are placed on the lining's durability and service life. In general, BOF service lives are 20 to 30 times longer than those of steel casting ladles. BOFs are the key items for steel production.

Magnesia-carbon bricks (MgO-C bricks) have become established as the standard material for refractory linings. With the increasingly higher demands placed on linings, the dolomite bricks previously used as an alternative have meanwhile been practically displaced due to their lower performance, so that MgO-C bricks have become the worldwide standard.

The following sectional views through a BOF show the typical locations of the individual zones, each of which is subjected to different loads and stresses.

2.1. Upper cone and mouth

The upper cone, i.e. the upper conical part of the BOF down to the barrel (Fig. 1), is an area subjected to very different loads. Brick wear is caused by abrasion from the passage of particle-laden gases, and also by oxidation due to carbon burn-off. Frequently, bricks are also torn out of the upper brick bond layers during cleaning operations. If these gaps become too large and can no longer be repaired with gunning material, the damage can even result in failure of the entire lining. To avoid excessive restriction of the upper cone, brick lengths of not more than 600 mm are generally used. Refractory materials



Fig. 1

with 97% sintered magnesite or large-crystal sintered magnesite + 5 – 10% carbon have proved their worth. In some cases, reinforcements with fused magnesite might be necessary in the mouth area.

2.2. Tapping area and slag zones

During tapping, and depending on production program and blowing model, the bath area is subjected to heavy and very heavy loads. It is possible that very hot and highly fluid melts and slags with a high FeO or oxygen content are in extended contact with the refractory lining. This can lead to progressive decarburization and the formation of low-melting compounds with decomposition of the brick substance. The introduction of corrosion-resistant fused magnesite with a proportion up to 100% provides highly effective protection for the brickwork.

Due to the continuous contact with the hot slag/ steel emulsion, the slag zone is also subjected to increased wear, particularly at the beginning and end of the blowing process, when the slag exhibits an increased FeO content. As a result of the BOFs different positions for the blowing and tapping operations, there are two separate slag zones. Particularly high loads occur in the slag crossover zone, i.e. the two intersecting points of the slag zones corresponding to the angled and vertical BOF positions (Fig. 2).



Fig. 2

2.3. Trunnion area

Due to the BOF being tilted, large areas of the refractory brickwork can become covered with calcareous slag. In this case, the slag has a protective effect, as it is enriched with MgO (mostly dolomite or dololime) and can solidify on the brick surfaces. Enrichment with MgO ensures that the dissolution potential of the refractory lining from MgO-C in the slag is reduced. However, the low filling level of the BOF means that the trunnion area (Fig. 3) cannot come into contact with the slag.



Fig. 3

Consequently, it is not possible to apply a protective slag coating on the refractory surface by tilting the BOF. But compared with the upper cone, the trunnion areas are subjected to higher temperatures, and are therefore exposed to increased oxidation. By increasing the carbon content to 15%, the brick is made particularly impervious. The high resistance to oxidation of the introduced flake graphite provides for delayed burn-off. Further protection is possible by the addition of fused magnesite.

2.4. Lower cone and barrel

The conditions in the lower cone (Fig. 4) and barrel (Fig. 5) are similar to those in the slag zone. Sometimes, individual zoning of the three areas is even omitted. The loads in these areas are slightly lower than in the slag zone, because the molten steel is less aggressive than slag. Refractories based on sintered magnesite with a percentage of fused magnesite are used here. Due to the higher local erosion around the bottom tuyeres, reinforcement might be necessary.



Fig. 4

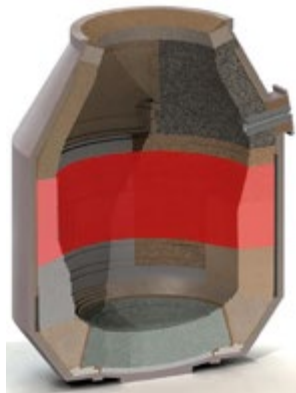

Fig. 5

2.5. Bottom

The bottom is subjected to high wear due to the continuous contact with hot melt, and the increased local erosion around the bottom tuyeres. Frequently, thermomechanical influences also play a role, in particular if the bricks' thermal expansion is hampered by excessively tight installation. Similarly, the bricks can be fractured by bending moments that can arise in hollow spaces in the dovetailed floor bricks (see Section 3.3.), and can fall out in case of continued refractory lining wear. Mostly, the lining bricks contain fused magnesite and are based on FM 97 and FM 98 with 10% carbon.



Fig. 6

2.6. Scrap impact zone

In most BOFs, the scrap impact zone (Fig. 7) is the most severely loaded area. Pieces of scrap metal that can weigh several tons each, fall onto the hot bricks from a height of 5 – 10 m. These heavy loads can only be resisted thanks to the strong composite brickwork. Additional loads occur, if the scrap impact zone (charging pad) is located on the same side of the BOF as the tap-hole. Apart from the mechanical loads, the zone is then also subjected to corrosion and oxidation. The best results are achieved with bricks based on 100% FM 98 plus 10% carbon, and reinforced with stainless steel fibers.



Fig. 7

3. Lining practice

3.1. BOF brick shapes

BOF lining bricks are the longest and heaviest bricks used in a steelmaking plant. Depending on the BOF's size, end arch bricks with lengths between 300 and 1200 mm are used; in some cases – particularly in Asia – even up to 1500 mm. Hereby, the layer height varies between standard 100 mm in Europe, Africa, the Middle East, and parts of Asia, and 76 mm (3 inches) in America and other parts of Asia. In Asia, also bricks with layer heights of 150 mm are used. Hereby, single bricks can weigh up to 80 kg.

The stepped surface in the conical BOF zones represent an unfavourable structure of the internal refractory surfaces, thereby providing possibilities for attack by wear, a reduction of the effective brick length in relation to overall brick length, and to undesirable thermal expansion of the exposed brick ends. Therefore, a special shape for lining the conical BOF zones has become established during the past years – the double-wedge end arch brick. Compared

A-side or cold side is the name given to the brick's wide side facing the safety lining; the narrower B-side faces the BOF's interior. Hereby, single bricks can weigh up to 80 kg.

with the normal end arch brick, the new shape exhibits a second (horizontal) wedging, which permits inclining the brick layers for lining the conical BOF zones.

The advantages are a uniform, smooth inner BOF surface with minimum wear areas, the opportunity of using the full brick length, and a more favourable distribution of thermal stresses.

Fig. 8 shows the comparison between a normal, stepped lining (left), and an inclined lining using double-wedge end arch bricks (right).

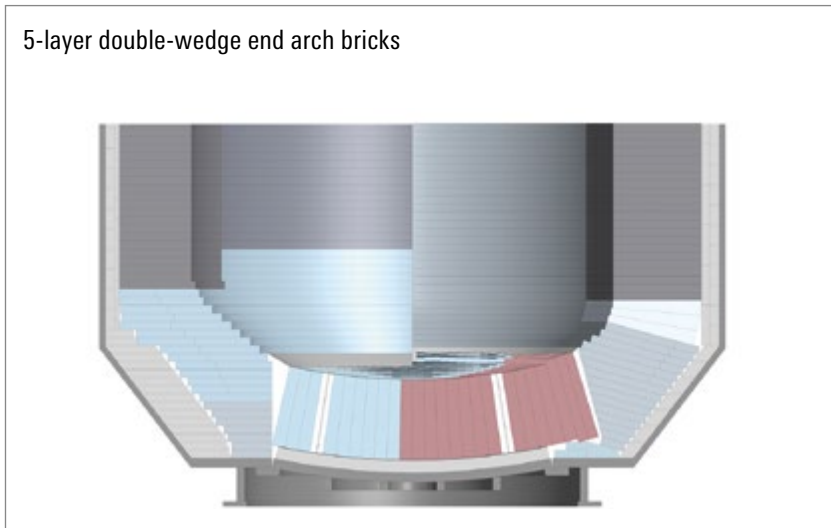

Fig. 8

Fig. 9 shows the double-wedge lining of the upper cone.

By using several layers of double-wedge bricks, the lining can be given an inward or outward curvature. The lining termination at the BOF mouth, and the transition to the bottom lining are then horizontal again. Because the increased tipping angle of the lining layers promotes slippage during installation, the brick surfaces are provided with a rough coating that reliably prevents them from slipping.

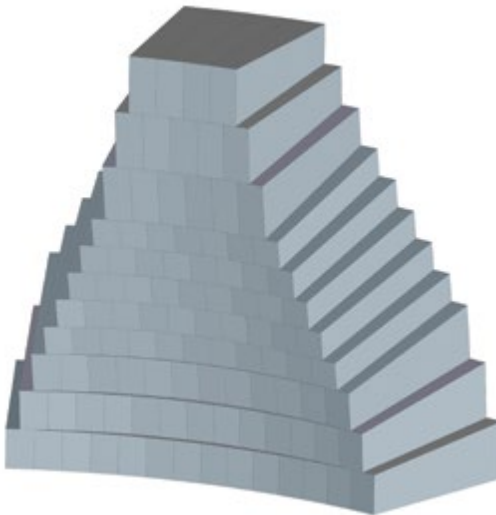

Fig. 9

3.2. Preparations for lining the BOF

The preparations for lining a BOF start with a visual inspection of the vessel. Different vessel shapes, BOF sizes, and processes mean that a wide range of lining versions is possible. Some of the steel shells have seen a service life of 20 years or more, which is why the shell is frequently deformed. Therefore, when planning the BOF lining, the first step is to determine the deformations together with the customer, which must then be taken into account when selecting the most suitable qualities and shapes. If deformations are not taken into account properly, this will result in errors when calculating the number of bricks required, and therefore to more expense during lining (re-cutting the bricks, etc.). With older BOFs, the reference measurement is a possibility for determining deformations of the steel shell. As a preventive measure, additional insulation and the preparation of ring tables and quantities can be carried out. Before starting with lining work, the wall area (wear lining) should be marked on the permanent lining.

For the reference measurement, the BOF vessel (without lining) is measured with a laser to obtain a basis for calculating the required brick shapes and to determine lining wear.

Starting vertically below the taphole, rule marks must be drawn on both sides, so that the exact center of the side opposite the taphole can be determined. Now the rule marks can also be used to specify the angle values.

Based on the information provided by the customer, the most suitable qualities for the BOF must be determined and recorded in the installation drawings for the refractory materials for later implementation. In order to prevent steps, projections or even gaps in the wear lining, the BOF must first be inspected in detail by the brick-layer foreman. In areas with larger shell deformations, the lining might have to be installed differently than specified in the drawings. For BOFs with removable bottom, a 20 – 30 mm thick level should be installed on the console that is inclined about 1 – 2° outwards towards the wear lining. The same principle applies for spiral installation, except that a concrete or steel ramp must be installed on the console.

In the construction business, a console describes a supporting ledge that projects from a wall.

In case a ramp is installed, it should be noted that it is inclined 0 – 100 mm. At a length of about half the circumference, a division into thirds or quarters must be made to ensure that the ramp's respective starting brick is laid up to the next brick.

Depending on the BOF's circumference, single, dual, triple or quadruple spirals are possible. Hereby it must be noted that the more spirals are used, the steeper will the run of the spiral be. This lining method has the advantage that no end bricks need to be cut. In spite of the difficult handling, care must be taken to ensure a tight joint below the mouth ring.

Tip:

By arranging boards at specified distances, the castable mix can be levelled evenly and smoothly.

Also a nail float can be useful for providing an even distribution.

A layer thickness of 30 mm is obtained with a nail spacing of 30 x 30 mm and a nail length of 30 mm.

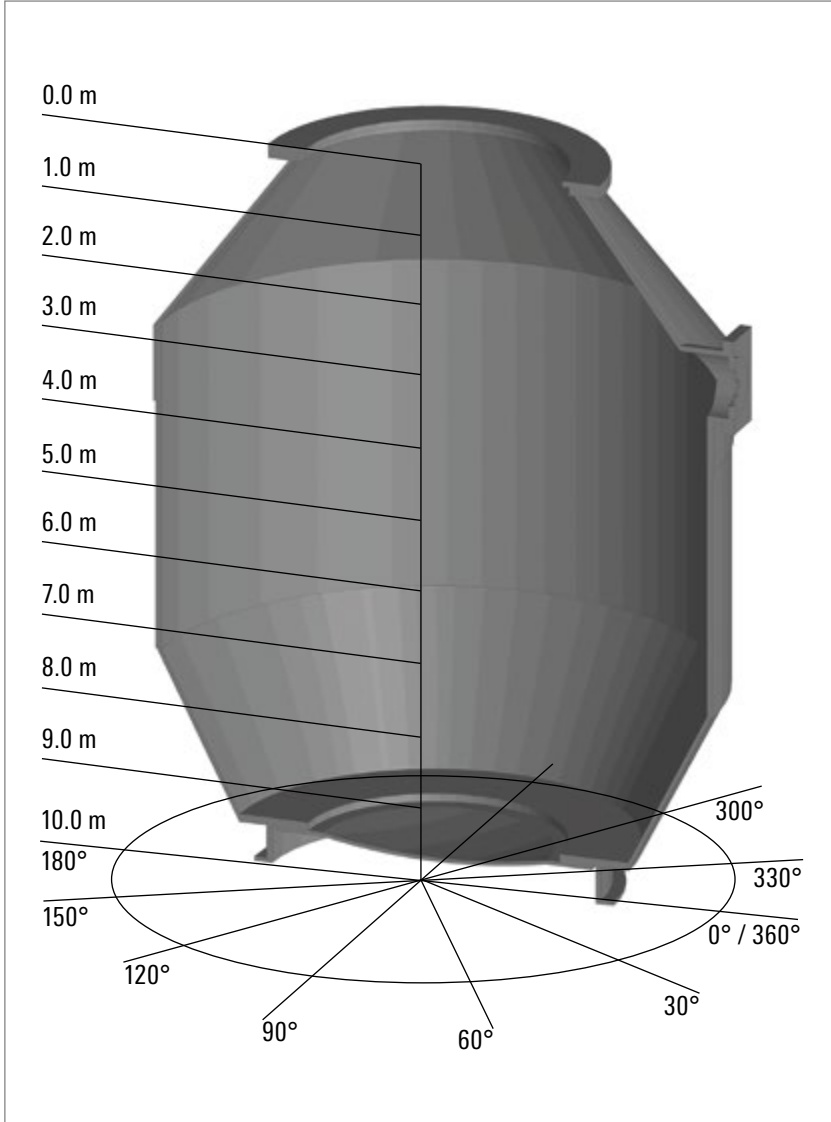

Fig. 10

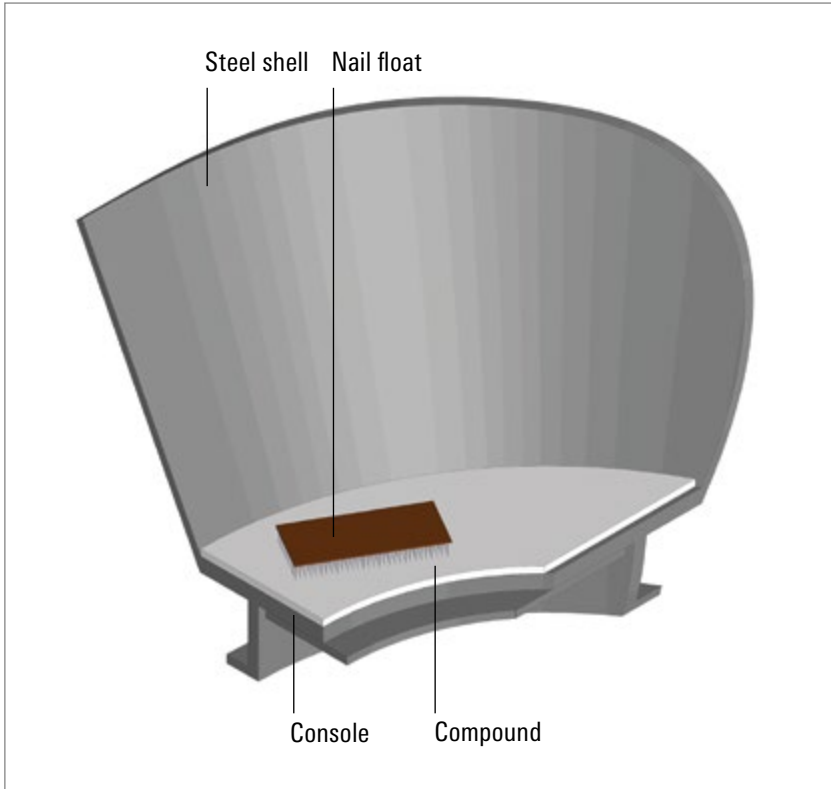

Fig. 11

3.2.1. Permanent lining

The permanent lining remains in the BOF for several campaigns, and serves as foundation for the wear lining and the safety lining. Fused MgO bricks as well as simple MgO-C types are used as refractory material. The permanent lining should always be given special attention. If installed correctly, and with corresponding horizontal and vertical consoles, the permanent lining can last for several wear linings. Larger joints and transitions on the consoles must be filled with basic mortar and castables. Primarily, this ensures additional rigidity of the vessel, as well as protection from high temperatures during the entire campaign. The permanent lining also serves as wear indicator in case of a fully worn out wear lining, and prevents a breakthrough of liquid steel.

After installing the first layer, the individual wear lining zones, i.e. scrap impact and trunnion areas, etc. should be marked on the permanent lining. By drawing a line meter by meter from the center of the taphole, one obtains the exact center on the opposite side, from which the zones can be determined.

An adaptation of the wear lining to the permanent lining must definitely be avoided, otherwise large steps can occur in the BOF lining.

Qualities, quantities, and the mixing ratio from the ring table should be indicated here.

The installation of rear backing in the BOF is one option for reinforcing the scrap impact zone. Thanks to the 100 mm thicker lining, a longer service life and good wear monitoring can be ensured, because the rear backing becomes visible as soon as the lining of the scrap impact zone is completely worn out. Suitable repair measures for this area can then be implemented immediately. The backing also provides additional protection of the lining from heavy impacts when charging the scrap. The taphole is mostly located in the transition area between barrel and upper cone. Here, it is always advisable to dry-install 4 to 5 layers of the specified brick shapes using one brick type at a time, and then determine how to implement the transition. It is also expedient to prepare a template for this area, in particular when lining with lifter shapes.

3.2.2. Installing the first layer in the BOF

Naturally, the BOF lining is installed from the bottom upwards. The first step is to apply a levelling course on the console. Hereby, a basic levelling material with a max. thickness of 30 mm should be used. When installing the first layer, it is important to keep the inside diameter free, so that installation of the bottom lining can be carried out without problems. Moreover, the BOF must be standing exactly upright. If this is not observed, the exact position of the console must be checked with a spirit level. Next, the first layer can be installed so that the distance to the mouth ring is the same at all points. If the castable material is not applied accordingly, the wall lining rings will be parallel, but there will be different gaps below the mouth ring, which in turn will lead to different castable thicknesses. During the entire lining procedure, it is important a heavily worn permanent lining is replaced, and wash-outs are filled and well rammed.

3.3. BOF bottom

3.3.1. Bottom designs

There are different types of bottom and bottom linings (with/without tuyeres)

1. Semi-hemispherical bottom with wall structure in the floor area and bottom joint (Fig. 12)
2. Closed bottom (dovetail) with rammed joint and lateral wall structure in the floor area (Fig. 13)
3. Closed bottom with rammed joint and dual-layer bottom lining (Fig. 14)
4. Closed bottom with side cuts for the wall structure (Fig. 5)
5. Full hemispherical bottom with integral wall structure (see Section 3.3.3)

The bottom lining must be started exactly in the center. To determine the exact center, one needs two cords that are stretched crosswise. A plumb bob is used at the intersection to determine the exact center, and to mark the position of the first brick. To prevent wedge-shaped joints, the bricks must be installed precisely at right angles. Depending on the inclination of the bottom cone, the gap at the edge of the bottom lining, on which the wall structure will rest, must have the same spacing at top and bottom.

In general, and depending on the diameter, every BOF bottom that is lined with a dovetail pattern should have the first three to five rows aligned in the same direction to provide better rigidity.

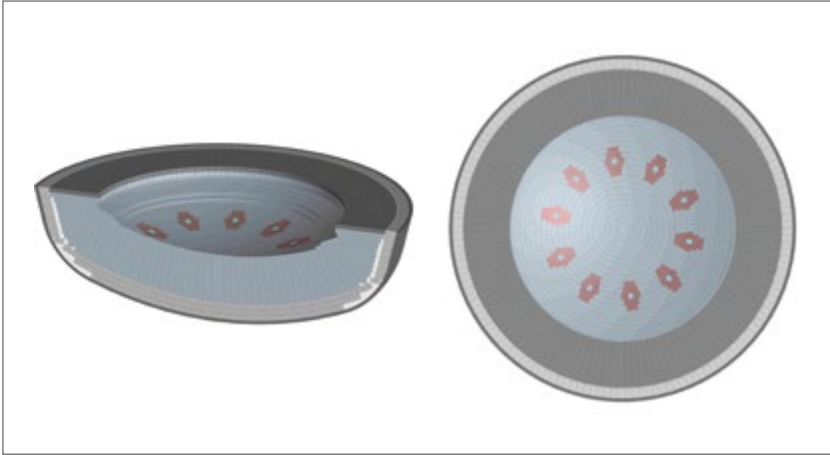

Fig. 12

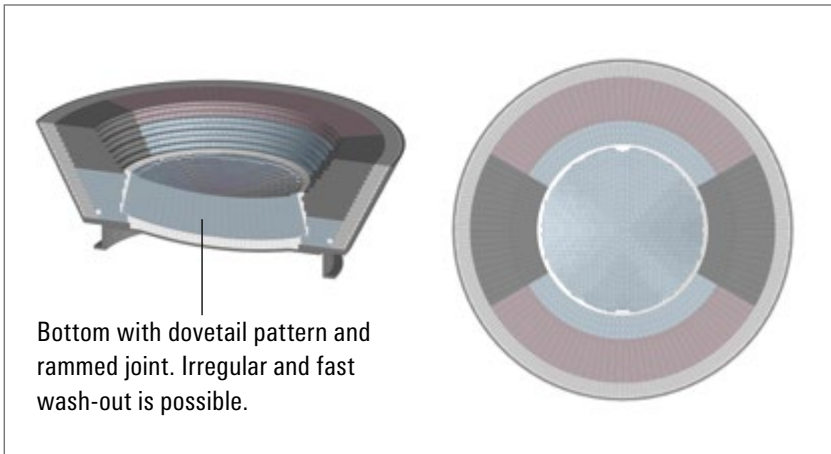

Fig. 13

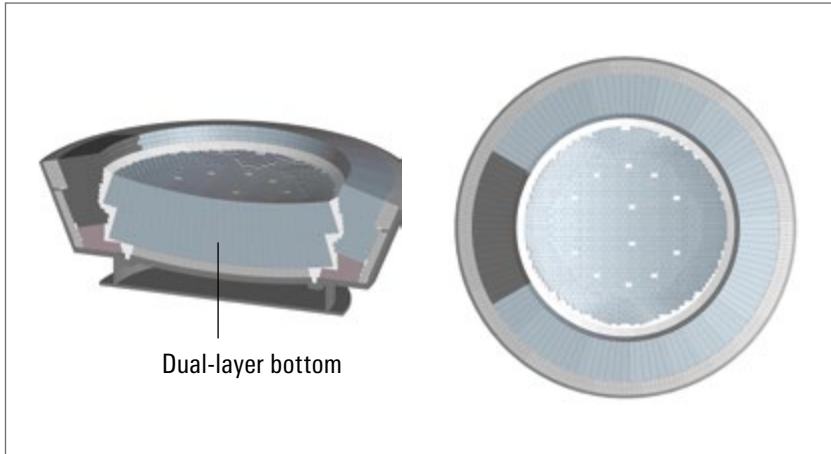

Fig. 14

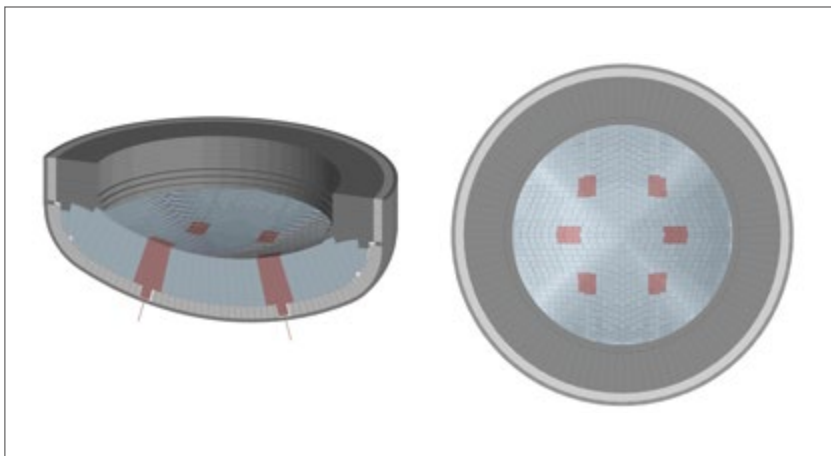
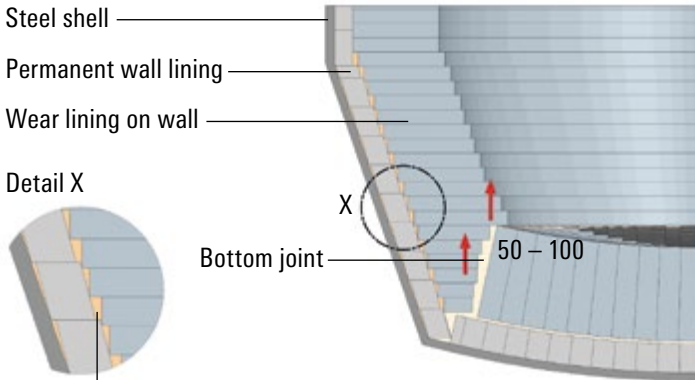

Fig. 15

Correct



Mix is rammed to the permanent lining to brace the layers.

A lower-quality compound than for the bottom joint can be used for backfilling.

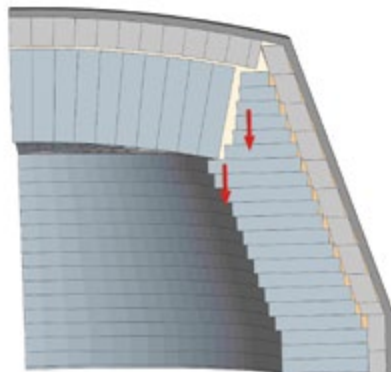

Bottom can lock to the wall when the BOF is tilted.

Fig. 16

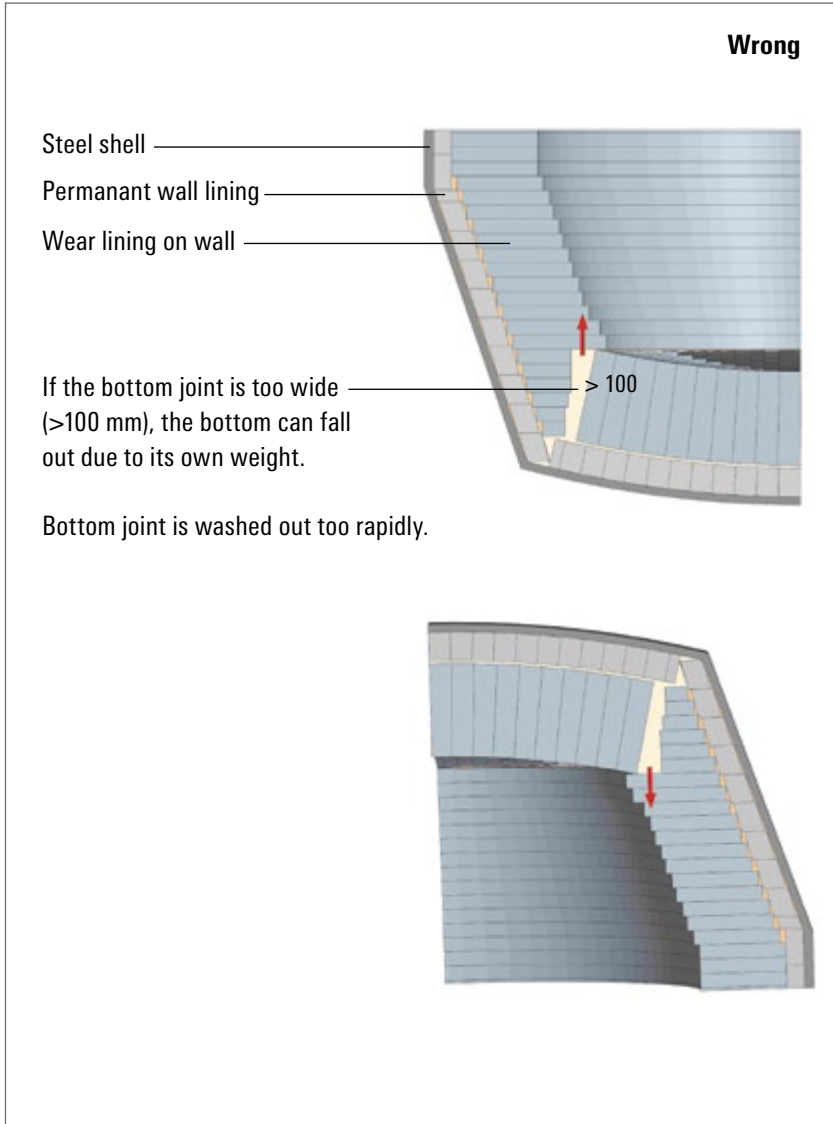

Fig. 17

To obtain a precise 90° angle from the first longitudinal rows to the transverse rows installed from the center point, a distance of 800 mm is measured along the first installed row. Next, a distance of 600 mm is marked on the transverse row, so that the length between the two end points is exactly 1000 mm (Fig. 18). In this way, one only needs a tape measure or a folding rule to install at a precise 90° angle. Installation of the bottom lining depends on the respective designs of the individual units in the plant. Fig. 19 shows the typical pattern of a dovetailed installation. To ensure the most even surface possible, the bricks must always be laid at an angle of 90° on the permanent lining. In this way, the pressure in the individual rings will be distributed uniformly onto the brick surfaces. Load pressures must be transferred to the permanent lining via the full A-side of the brick. If the bricks are skewed, steps and edges on the inner and outer surfaces of the permanent lining will be created. This will result in peak loads and thereby possible cracks and fractures on the inner surface of the permanent lining (B-side of the brick).

Tip:

To obtain a cross, a cord is stretched across the BOF from 0°/360° to 180°, and from 90° to 270°

Pressure from the brick's A-side to the permanent lining is only applied at discrete points instead of the entire surface. Moreover, the specified mix in the layers should be observed, as the bricks could otherwise arch over or under. However, in deformed areas, the mix can deviate and might possibly have to be adapted.

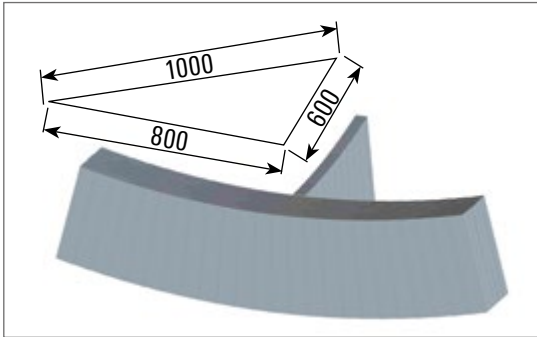

Fig. 18

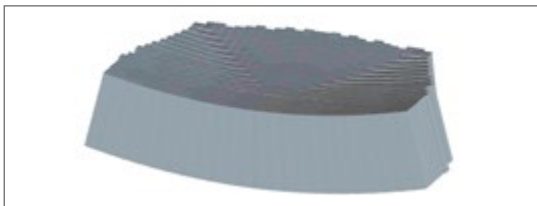

Fig. 19

3.3.2. Rammed joint

With conventional BOF linings, the transition from bottom to wall is marked by a ramming joint (Fig. 20). This joint provides the anchor between the bottom and wall linings, and thereby secures the bricks from falling out when the BOF is tilted. It also serves as compensation between wear and permanent linings, absorbs tension forces, and is an important element for maintaining the BOF's rigidity and service life. In addition, it also has an insulating effect to a certain degree (heat flow through the wear lining bricks).

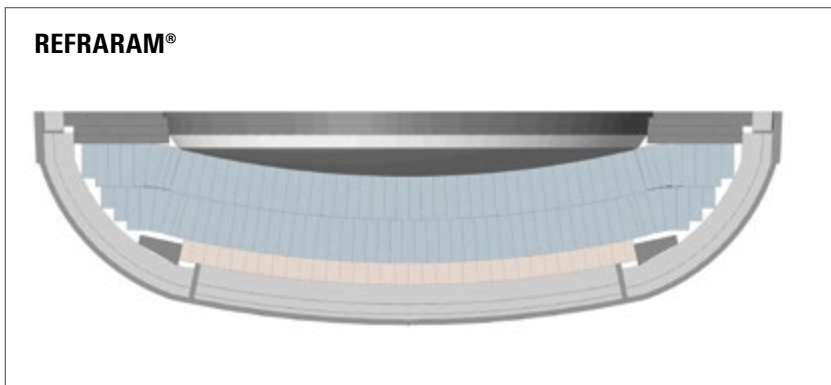

Fig. 20

Basically, the rammed joint represents a weak point in the BOF, as rammed MgO-C material does not have the same properties (strength, open porosity, slag resistance, etc.) as pressed bricks. Therefore, great care must be given when installing the rammed joint. Good and dense ramming ensures that the individual layers are mutually tensioned, and the bricks are forced in the wedge direction, whereby possible gaps are closed. But the installation of a rammed joint also has advantages:

1. Deformations in the wear lining can be compensated. Smaller steps are obtained in areas that have come out of shape. Larger sections, mainly in segments with higher liquid metal movement, ensure that the usually projecting brick material is subjected to a higher wear rate.

2. Abrasion of the wear lining and resulting open joints can lead to finning. The liquid metal can spread out in the rammed joint, thereby protecting the permanent lining.
3. The rammed joint absorbs the thermal expansion of the bottom bricks.
4. Faster and better demolition of the BOF's wear lining.
5. Protection of the permanent lining during demolition.

When installing the rammed joint, it must be noted that the joint width may not be less than 20 mm and not more than 80 mm. Therefore, to obtain good compaction on the one hand, but not allowing the joint to become too wide on the other, an average width of 50 mm should be aimed for. Ramming should be done in three layers that are evenly filled with ramming mix and then compacted well. Every ramming stage is done so that the joint is flush with the next layer, i.e. usually about 100 mm deeper, so that the layer can be swept clean to the rear.

No cavities are permitted, to prevent the ramming mix sinking in during the BOF campaign due to bad compaction. Any spaces will enable the bricks of the wear lining to be pushed to the rear, thereby creating open gaps.

When ramming the rings, it is important to start at the permanent lining before ramming between bottom and wall structure. Ramming on the permanent lining side will press the bricks inwards, thereby giving additional tension to the ring and closing the gaps tightly. The ramming mix must be applied in layers, should not be higher than 300 mm, and can first be distributed evenly with a board. During ramming, it is important that the entire surface is included. For faster and better working, it is advisable to use two ramming hammers. This also permits the subsequent layers to be swept clean, and ensures continued horizontal installation.

3.3.3. Special case: Full hemispherical bottom

Full hemispherical bottoms require a very complex installation technique in the BOF. The lining features a seamless transition from bottom to wall. Hereby, the critical bottom joint is omitted, together with the extra ramming work involved. However, the tension-compensating effect of the rammed joint is missing. Fig. 21 shows the principle of lining a full hemispherical bottom. Production of the bricks for this type of bottom is elaborate, but the installation work is simple and fast. The bricks are manufactured as double and single-wedge end arch bricks, then pre-installed on a dished steel plate with the BOF's geometry, form-fitted precisely by cutting and grinding, marked with position numbers, and then packed onto pallets in accordance with

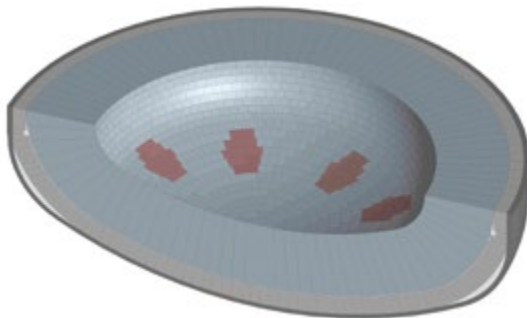

Fig. 21

the installation pattern. During lining, the numbered bricks are then installed in the correct sequence like a construction set. If the bricks are stacked on the pallets accordingly, it is possible to install them simultaneously at two positions in the ring, which greatly reduces the installation time.

Installation starts with the king brick, a polygonal brick or truncated cone that is placed in the center of the BOF bottom, and from which the lining with mated bricks is installed circular radially. Thanks to the perfect form fit of the bricks, bending stresses and pin-point loads are avoided. The entire thermal expansion of the lining is transferred up to the mouth via the cylindrical part. If provision is made for upwards movement of the lining, the full hemispherical bottom is the optimum solution for BOF lining – both in terms of stress and also the composition and density of the lining pattern.

The king brick must be placed with utmost precision. Any error when positioning the king brick will lead to great problems when lining the remaining BOF.

First of all, the permanent lining must be thoroughly cleaned. Next, all remnants of steps, steel and slag deposits, or high spots must be removed from the permanent lining. The center point of the bottom is determined by means of markings on the permanent lining (division into quarters or eighths). Subsequently, a layer of castable mix, 10 – 20 mm thick, is spread onto the permanent lining to level out any unevennesses. The bottom lining has no direct contact with the permanent lining. Simultaneously, the levelling layer enables the bottom bricks to be installed without steps on the hot side.

But first, the central point for the king brick at the intersection must be determined with a plumb bob. The king brick is then centered, i.e. it must be absolutely vertical. The brick's vertical position is determined as follows:

1. Place a spirit level horizontally on the brick, and fix the brick. The brick's upper edges must be precisely manufactured.
2. Check the position by placing the spirit level on the brick's A-side and ensure the same distance above the B-side in 4 directions. A spirit level with graduations in degrees is ideal for this purpose (Fig. 22).

If the king brick is not absolutely vertical, this will have severe consequences for the entire lining. The bottom would be sloped, and therefore the wall lining would not be horizontal.

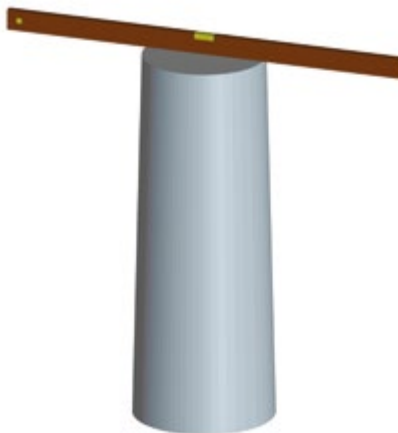

Fig. 22

The king brick and the respective first bricks must be marked on top with a white line. If these marks align precisely in every ring, also all subsequent bricks will fit accurately without gaps from the previous ring. Only whole bricks should be used around the tuyeres – cut bricks can be used between the tuyeres. If necessary, a suitable mortar can be used, but it must be applied over the entire joint and not only at the edges. On the permanent lining side, every ring is filled with ramming mix and compacted. Ramming should be carried out according to the drawing.

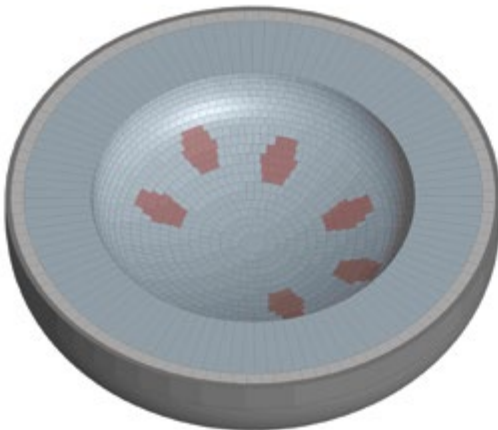

Fig. 23

Any deviations must be discussed with customer, entered in the drawing, and also marked if necessary. The ramming gap must be free of all foreign material such as wood pieces, cardboard rests, brick debris, etc. To ensure a good ramming density in the layer offsets, not more than 3 layers with a height of 300 mm should be installed. These are filled with ramming mix.

The correct angle and the right length (depending on device) are also required for correct installation in the taphole zone. Moreover, the importance of perfect installation without skewing the bricks must be pointed out again. In addition, the bricks must be fitted accurately around the taphole by cutting them to size. Also, a suitable refractory mortar must be used in this zone. When cutting the bricks, care must be taken to ensure that more than half the original brick size is maintained. The BOF's actual spherical shape is obtained by using ribbed bricks in the lower cone and taphole areas. In this way, a smooth internal surface finish can be ensured in the entire vessel to obtain better flow conditions.

Furthermore, spalling and slag accumulations in the taphole area are avoided. With these bricks, there is no need to use any mortar. They are simply installed at angles up to 25 degrees. However, a clean finish of every layer is necessary, particularly in the taphole zone.

3.4. Oblique installation in upper cone with double-wedge or end arch bricks

The double-wedge brick shapes required for oblique installation have already been mentioned in Section 3.1. Double-wedge layers come in plus and minus versions, depending in which direction the layer is to be diverted. Here, 'plus' stands for the higher side. When working with double-wedge bricks, particular attention must be given to the lower layer to ensure that the bricks have a secure hold. For this purpose, bricks with ribs, a rough coating to prevent slipping, or special adhesives are used. Bricks cased in sheet metal can also be used.

If the bricks slip, moist paper can be used as a provisional underlay, or fixing clamps can be made. Flat metal bars can be used as clamps, which are hooked behind the lower layer to prevent the brick slipping.

Equally useful are end arch shapes (e.g. 90/80), as they can be cut vertically or as wedges for use as a substitute if double-wedge bricks cannot be used for some reason or other. This approach is also suitable to replace missing end bricks. Long end arch bricks can also be used to resolve a lack of pointed and blunt sizes.

It is also possible to secure the layers by means of an auxiliary tool that can be easily produced. The clamp can now be placed on the brick, where it hooks onto the A-side behind the last brick of the last layer. The angle of the flat metal bar on the B-side prevents the brick slipping. Depending on the BOF size, one needs 20 clamps, which are relocated alternately until the ring is closed. The same procedure is then used for the next ring.

In order to estimate at an early stage how the final layer below the mouth ring is to be installed, we recommend a design with three to four layers. A gap of not less than 40 mm and not more than 140 mm should be provided between the last layer and the bottom edge of the mouth ring. The last ring should be started so that the end brick can be fitted in the most convenient point on the mouth ring. This area must be very well rammed so that the ramming mix cannot fall out during tilting and charging. Hereby, attaching a thin metal sheet after ramming on both sides of the tilting direction can be helpful.

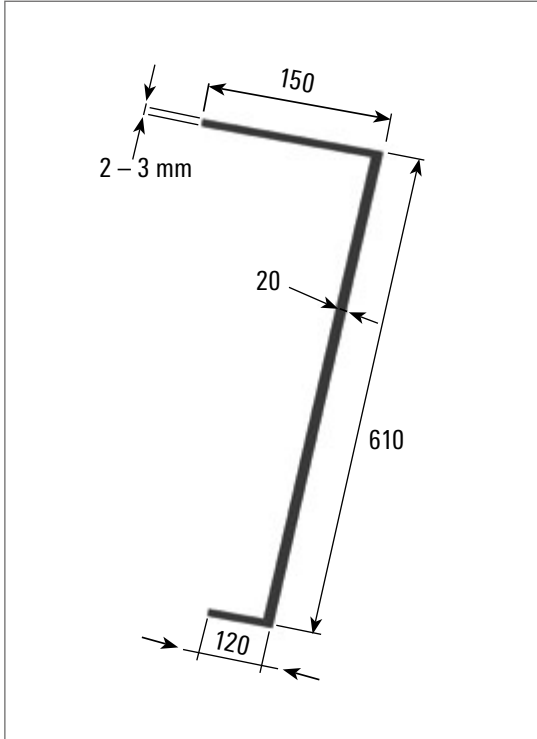

Fig. 24

Making an auxiliary tool (Fig. 24): Clamp, e.g. for end arch bricks, brick length 600 mm.

Flat metal bar (2 – 3 mm thick, 20 mm wide) or round bar 8 – 10 mm \varnothing ; length 610 mm
A-side angled 150 mm;
B-side 120 mm.

End arch brick, cased in sheet metal

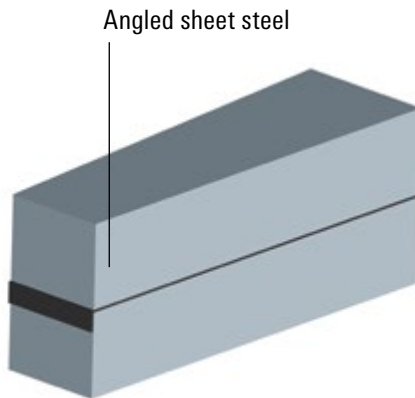
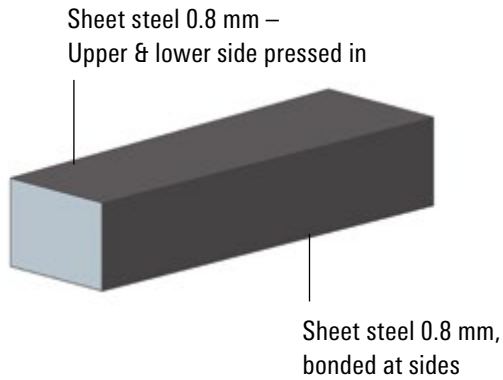

Fig. 25

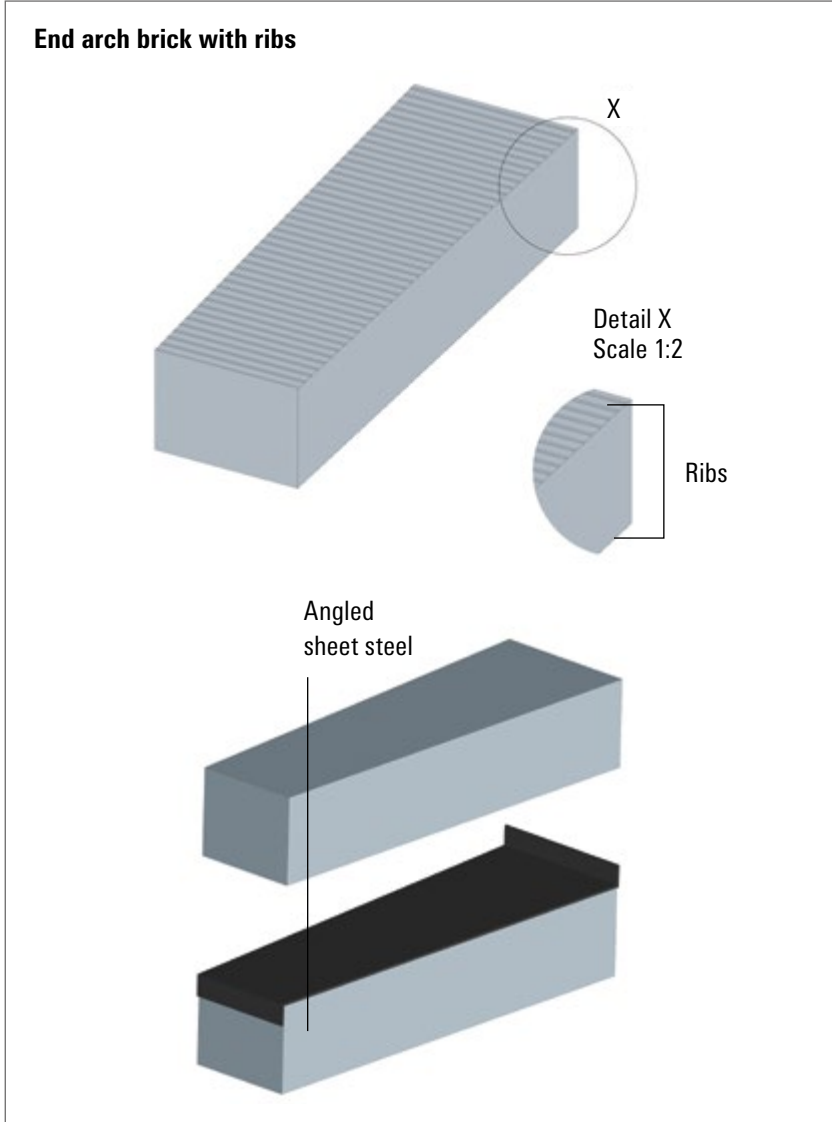

Fig. 26

3.5. Lining the taphole

The taphole should be lined before lining the upper part of the cylindrical BOF barrel. This avoids unnecessary physically strenuous and unsafe work. Subsequently, this area must be undercut cleanly and installed in a half offset pattern. The bricks above and below the taphole are then cut to size, taking the angle and inclination into account. In case of an almost horizontal taphole, we recommend placing the end arch bricks upright and marking them for cutting, so that a clean and straight termination of the layers is obtained.

The taphole area should be lined using mortar, as brick saws frequently do not cut at a precise angle, which can result in open gaps or fractures in this area.

The BOF is then rotated towards the BOF platform, so that a pipe with the diameter of the inner sleeve can be fixed centrally in the taphole opening. Finally, the BOF is rotated further until the inserted metal sleeve is vertical. In this position, the inner sleeve and the blocks are

installed using in-and-out bonds so that there is no continuous joint between inner sleeve and block.

By using this installation method, the taphole block has a secure hold, and the joints overlap so that there is no weak point. Hereby, it must be ensured that the inner sleeve is installed at right angles, to avoid damage to the block when replacing the inner sleeve.

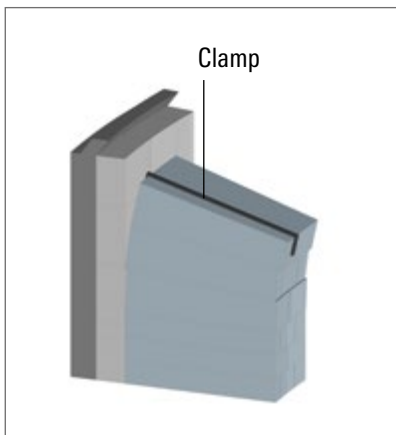

Fig. 27

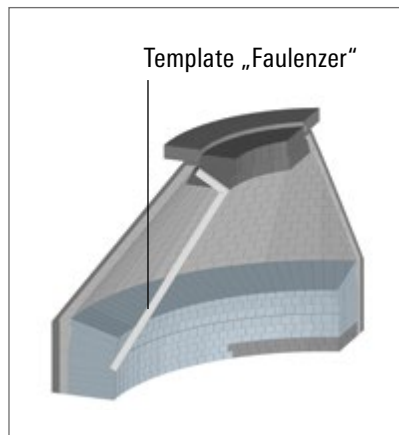

Fig. 28

When installation has been completed, a steel plate is fitted and welded to the pipe. In addition, two angle irons or round bars are welded at the sides, angled upwards to the mouth ring at 45 degrees. The tapping box projecting outwards can now be rammed with castable mix. Subsequently, the BOF is rotated to the working position, so that so that lining of the barrel can be started.

Pre-installing the taphole lining first has the advantage that a cord can be strung from the taphole to the first layer, and this area can then be lined with a flat surface. Accordingly, the steel shell – which is usually curved outwards in this region – can be lined with a flat surface. Now, no residual steel remains when emptying in the BOF. If the lining only follows the safety lining, a hollow will be greater below the taphole, in which residual steel will remain, as the BOF cannot be tilted further for complete emptying.

Because the taphole is subjected to extreme loads, it must be lined with a suitably strong type of brick. Taphole wear is due mainly to the turbulence occurring while tapping the molten steel. This turbulence wear can increase the taphole size, which can have negative results. The tapped spurt is too large, and therefore too heavy for the impact zone of the casting ladle. Also the slag stoppers are impaired, so that increased slag attack and slag discharge with the steel are the result. Therefore, the inner sleeve is usually replaced after a specific (plant-dependent) number of tapping cycles. When replacing the sleeve, chiselling, hammer drilling, or cutting with a hollow drill bit are the alternatives. When chiselling or hammer drilling, enormous pressures are generated when working from outside towards the inside. Adjacent bricks are highly stressed, which can cause fractures. In the worst case, the bricks can even be pressed into the interior of the BOF. For this reason, cutting with a hollow drill is the best alternative. The advantages of this method are obvious: No vibrations, and a uniform diameter for a precise installation of the inner sleeve.

The drill is a hollow, water-cooled tube of the required diameter, whose front end is tipped with hardened steel or diamonds. It is held and guided by a corresponding device, and as it rotates, a motor presses it into the brick.

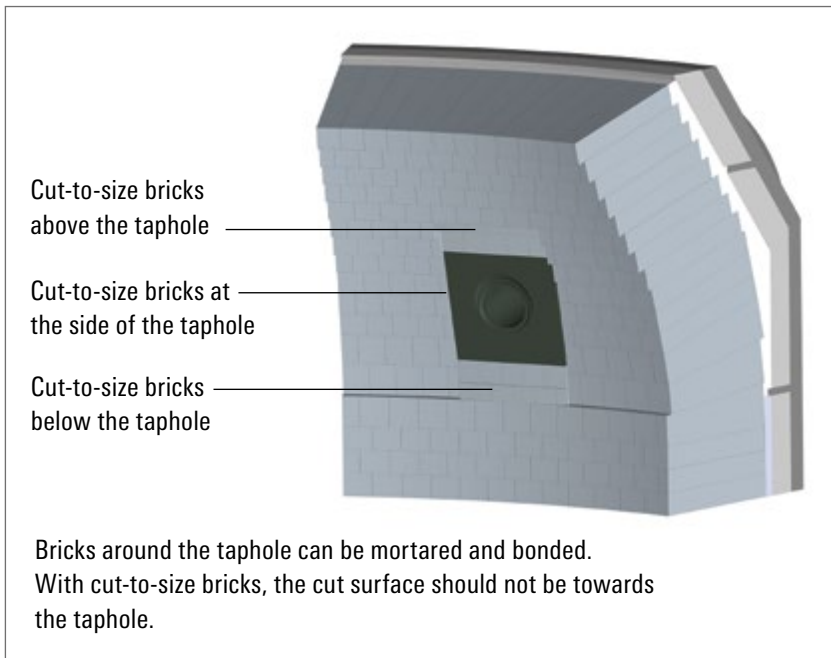

Fig. 29

During casting, it is important that the compound penetrates through to the cold side. To ensure a good seal on the inner sleeve, the sleeve should be heated before casting.

If the inner sleeve is preheated, casting can be started immediately, thereby saving time. At the same time, a large area around the taphole inside the BOF should then be cast or gunned to ensure a uniform cast. A good method for sealing the inner sleeve after a replacement, is to ram the mixed compound from the cold side to the hot side. After installing the inner sleeve, this is best done through filling holes provided in the steel plate fitted to the BOF. This ensures that no cavities are formed. Moreover, less water is required, so that the compound can cure faster and more densely.

3.6. Expansion compensation

Due to the relatively high thermal expansion of MgO-C bricks, the BOF lining is subjected to considerable stresses during operation. Some of the stress is necessary for an effective clamping of the brickwork and therefore for its rigidity, while another part of the stress is compensated for by the simultaneous expansion of the steel vessel. If no cardboard were to be inserted between the bricks in a BOF that has 70 – 100 brick layers, the expansion in direction of the upper cone up to the mouth would be so high that the bricks would be under great stress, which can lead to destruction of the lining if the stress exceeds the brick strength. This applies in particular to the trunnion zone, where additional mechanical stresses occur. Another danger is that the expansion could also push the taphole upwards.

To prevent spalling and stress fractures in the lining, the installation of cardboards in butt joints and layer joints is essential for expansion compensation in the BOF.

To prevent excessive stresses, partial compensation is achieved by providing additional space by inserting combustible material such as e.g. cardboard between the bricks during installation. The cardboard is inserted in the butt joints as well as the layer joints. The insertion of cardboard should begin about two layers above the bath zone. To compensate for thermal expansion stresses with conventional horizontal installation, the insertion of 0.8 mm thick tar paper is mandatory after every 3rd brick in the ring.

With BOFs in which also the upper cone is lined horizontally, this combined use of cardboard should be used up to the mouth ring. This is not necessary when installing deflector bricks (double-wedge shapes). Due to the angled installation, gaps of 2 – 3 mm (closed at top, open at bottom) are created at the butt joint of every brick, which close during heating up, thereby providing adequate compensation.

However, because of this one-sided loading, the bricks are subjected to a certain amount of bending stress, which must be taken into account.

Although sometimes omitted in practice so that the bottom lining is not weakened, cardboard should also be inserted between the horizontal layers of the scrap impact zone. Otherwise, the lack of space for expansion can result in cracks, brick attrition or spalling. What's more, if 2 mm thick cardboard is installed every 4th or 5th layer, the difference in layer height after 35 layers can be 15 – 20 mm if no cardboard is used in the scrap impact zone. Thereby, a step is created in the impact zone, which then forms vertical open joints on the left and right sides.

During heating up, it is important that the brick can first expand on the B-side. Expansion towards the brick's A-side occurs a while later, because it takes several heats before the bricks are fully heated. Also here, space for brick expansion must be provided, particularly when installing directly on the permanent lining. With backfilling, the bricks are also able to expand rearwards. The ring's diameter increases, thereby reducing the ring stresses.

The problems described above are even greater in full hemispherical bottom linings. A bottom with a rammed joint offers enough play for the bottom to expand into the joint. Due to this expansion, the area between bottom and wall is compacted even more, which prevents the bricks falling out. No cardboard is used here, because this would cancel the pressing effect, and the clamping force might no longer be strong enough. A full hemispherical bottom only offers limited space for expansion in the lower cone towards the permanent lining.

Cardboards for horizontal expansion must have large surfaces that extend across the entire brick length.

Example:

Brick 800 mm long,
cardboard 2 x 850 mm

A-side 800 mm

B-side 700 mm.

Consequently, these forces are shifted towards the wall or BOF mouth. The thermal expansion of MgO-C (about 1.5% at 1200 °C) results in a movement of several centimeters.

3.7. BOF topping versions

The last layer of the mouth ring is topped by ramming or gunning to complete the top edge of the BOF. This varies, depending on the size of the vessel. Fig. 30 shows the different versions for topping the BOF, and Fig. 31 shows different methods for placing the end bricks.

The vertical positions of the last two rings at the BOF mouth, enables them to be combined easily. This provides a connection that has proved its durability particularly during cleaning. Hereby, it must be noted that the same shapes must be placed above each other. Moreover, cut bricks should be marked after sawing. Although this involves more time during lining work, strength will be increased.

By avoiding steps in the last lining layers, slag adhesion, brick fractures, and raised layers can be prevented. Fig. 32 shows three different versions.

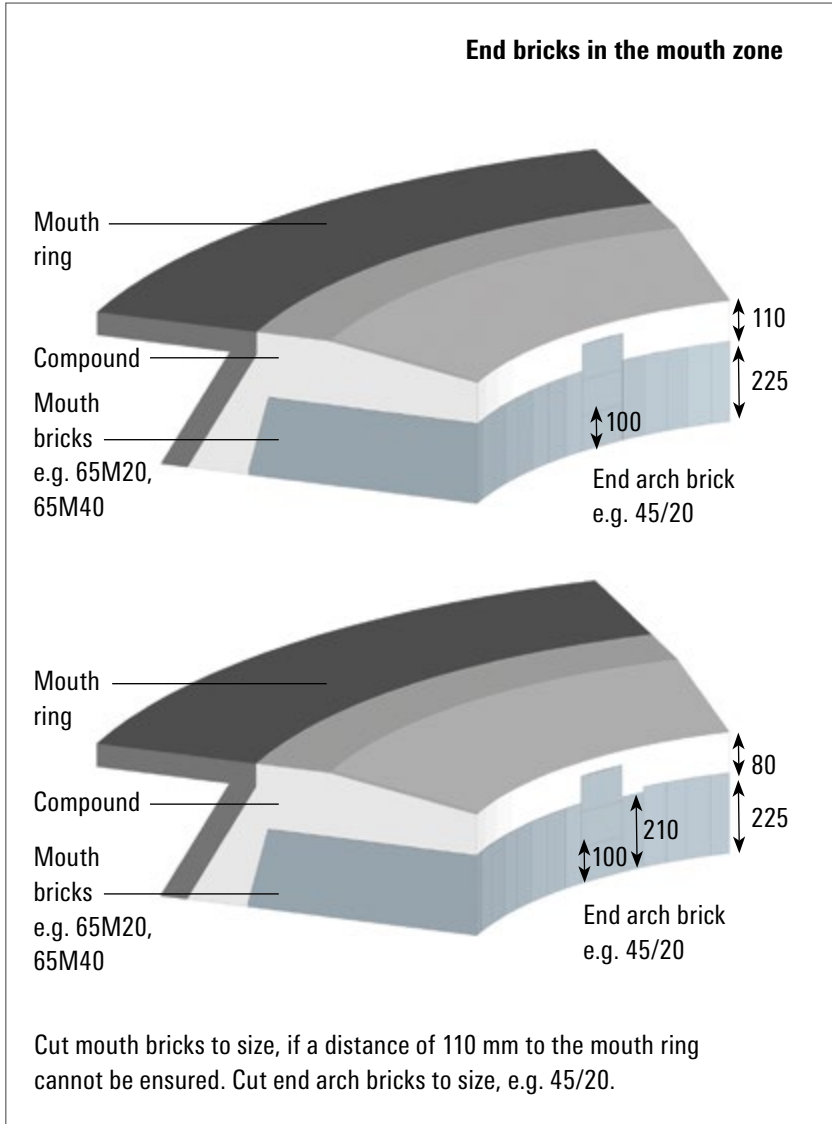

Fig. 30

Mouth area

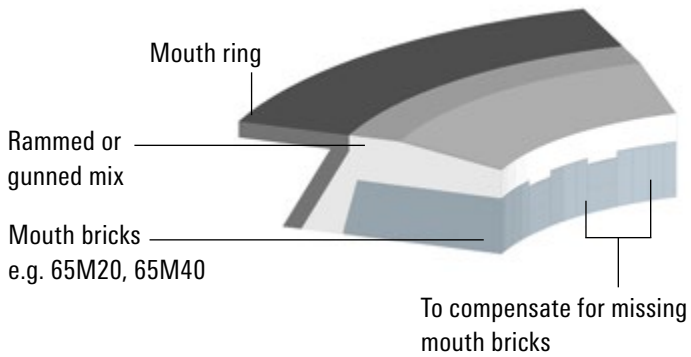
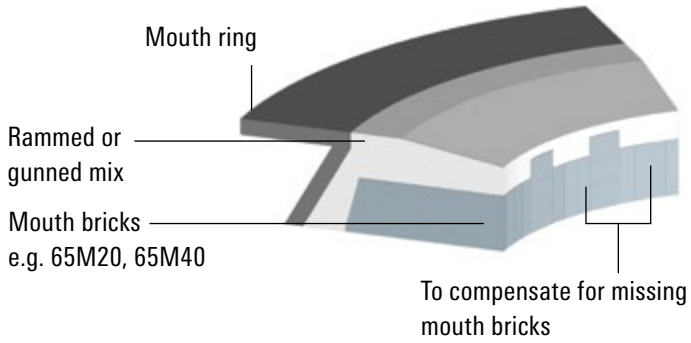
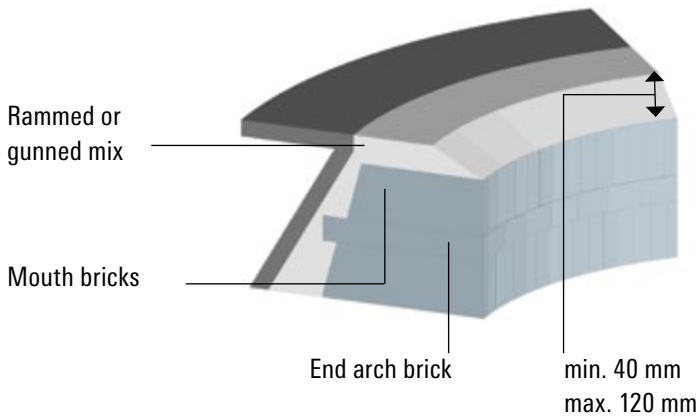
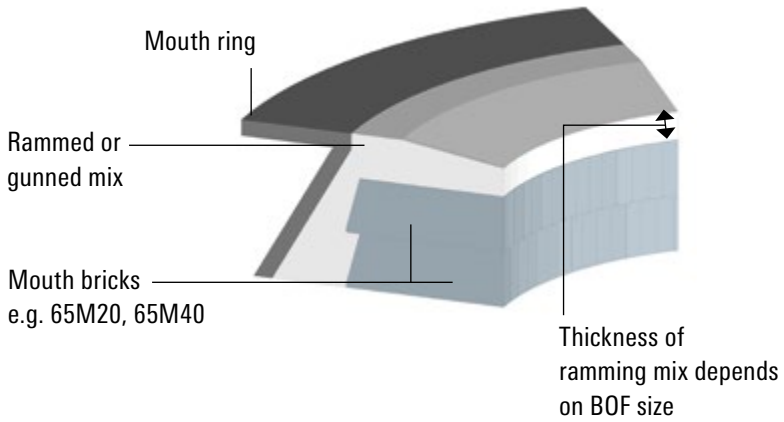

Fig. 31



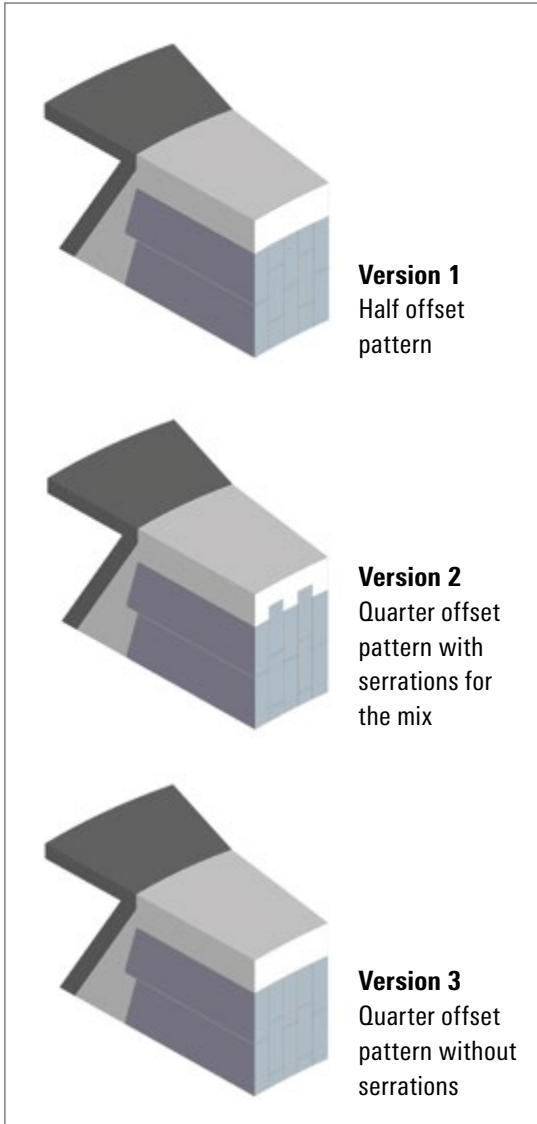

Fig. 32

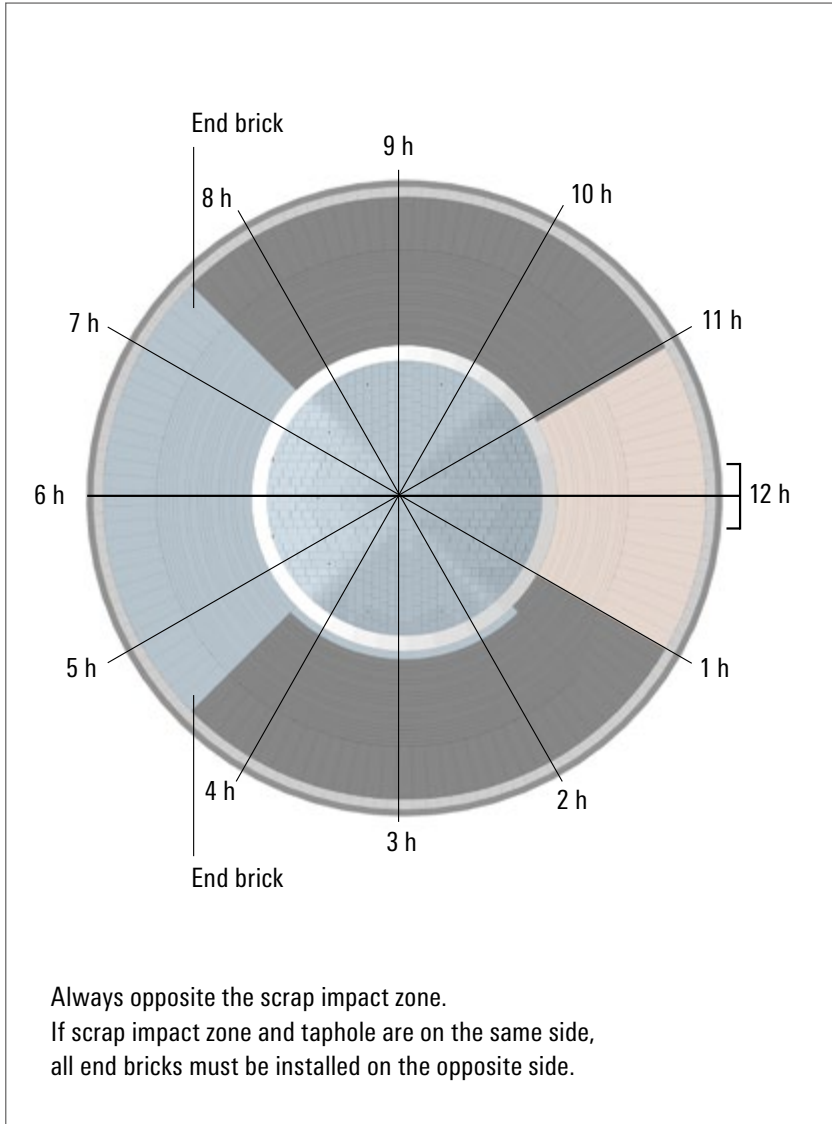

Fig. 33

3.8. Heating the BOF to operating temperature

Preheating the BOF must be done with utmost care and attention to prevent damage to the lining (see Section 3.6. Expansion compensation). In particular, any unevennesses that overarch the bricks, inaccurate insertion of the expansion cardboard, as well as large steps in the wear lining must be avoided, otherwise the heating up process will be irregular, leading to differences in expansion and resulting stresses. In turn, this can cause spalling and cracking in the brickwork. The following four main requirements must be fulfilled:

1. Maximized BOF availability
2. Minimum heat input into the refractory lining, to ensure that the first heat of molten pig iron can be blown
3. Minimized thermal shock loading during the first charging with molten pig iron
4. Minimized decarburization of the refractory lining

Slow heating up is required to increase the heat input into the refractory lining, and to minimize the thermal shock loading, but this conflicts with the requirements for maximum availability and minimum decarburization of the refractory lining.

In the past, a rule of thumb was to achieve a surface temperature of about 1330 °C for the first heat, i.e. comparable with the temperature of molten pig iron. This was necessary with ceramically bonded linings, and later also with pitch-impregnated linings to prevent large-scale spalling during the first and the next 30 heates. However, today's MgO-C refractory materials are far more tolerant in terms of thermal shock resistance. This is due on the one hand to their more elastic bond with plastomers and thermo-setting plastics, and to their higher thermal conductivity on the other.

BOFs have capacities up to 400 tons. However, compared with steel casting ladles, and in spite of their size, they need a relatively short heating up time that ranges between two and six hours. Heating up is done by burning coke with injected oxygen. Hereby, the oxygen is injected onto the coke through an oxygen lance. Due to the reaction of C with O_2 , the coke is ignited. In this way, the refractory lining temperatures required for charging the BOF with molten pig iron (more than 1100 °C) are achieved. Initially, a large amount of the coke in the BOF reacts, after which certain amounts are added at intervals. This is done either with the scrap charging box above the BOF mouth, or via the lime/ore chute. Dwelling phases are introduced during the process, in which the temperature is kept constant for a certain period. Simultaneously, the lance position is changed during the entire heating up process, so that the BOF's volume is heated accordingly.

Also here, the final temperature is about 1000 to 1200 °C. Every steel plant has its own refractory heating diagrams, which are based on experience and vary from plant to plant. Heating up is done mainly with coke and oxygen, whereby the height of the oxygen lance is varied. With bottom blowing converters, also natural gas and oxygen are blown in through the bottom tuyeres. The following table summarizes the most important parameters of typical steel plant-specific heating up procedures.

General recommendation for heating up – linear heating during four hours, with a specific coke quantity of about 25 kg/t rated capacity, and an oxygen quantity that results in a Lambda value of about 2 during combustion

Steel plant	Rated capacity [to]	Rated capacity [kg/t]	Oxygen [Nm ³]	Coke quantity [kg]
A	60	3.0	50.0	7200
B	90	2.5	27.8	9600
C	180	10.0	55.6	34500
D	185	3.8	20.3	27600
E	200	6.0	30.0	10200
F	210	4.8	22.9	14400
G	230	5.0	21.7	8760

The table illustrates the very wide range of parameters, so that a universal recommendation for heating up cannot be given. Even though a dependency between the amount of coke used and the BOF size is shown, the actual amounts vary from 21.7 up to 50 kg coke/ton referred to the rated BOF capacity. Even more difficult is the attempt to find a dependency between the amount of oxygen used for heating up, and rated BOF capacity.

Lambda	Heating time [min]	Heating rate [°C/min]	Surface temp. before first charging [°C]
1.46	480	2.7	not known
2.33	240	5.4	not known
2.10	420	3.1	1000
4.47	240	5.4	not known
1.03	240	5.4	not known
1.82	240	5.4	not known
1.07	120	10.8	not known

By calculating the Lambda value, i.e. the fuel/oxygen ratio with reference to the stoichiometric combustion to CO_2 , it is possible to estimate the flame temperature. The highest flame temperature is achieved with stoichiometric combustion and a Lambda value of 1. Flame temperature then decreases with an increasing Lambda value. The values lie between 1.03 and 4.47. The last two columns show the time required for heating up, and – due to the unknown real surface temperatures before first charging – the theoretical

heating rate to the temperature of molten pig iron. Accordingly, between 2 and 8 hours are required for heating up.

The theoretical surface heating rate to the temperature of molten pig iron varies between 2.7 and 10.8 °C/minute. However, as the surface temperature before the first heat is usually far below the temperature of molten pig iron, the highest thermal shock occurs during first charging. In Plant C, for example, a surface temperature of only 1000 °C was achieved in spite of a heating time of 8 hours and the combustion of 10 tons of coke.

The next higher heating rate of up to 20 °C/minute is then achieved during the first blowing cycle from molten pig iron temperature to tapping temperature. The table shows that the most extreme heating up conditions are found in Plant G.

The lining heat-up is achieved within just 120 minutes at practically stoichiometric combustion, i.e. maximum flame temperature. Although this means that the aim of heating up mentioned above, namely to raise the surface temperature close to that of molten pig iron, cannot possibly be reached, MgO-C bricks are able to withstand the enormous thermal shock of the first heat, thanks to their high heat conductance and their flexible bonding.

However, this approach is not recommended – also for ecological reasons. With practically stoichiometric combustion the pyrolysis gases escaping from the lining cannot be converted completely to CO₂ and water, which is why the emission of environmentally harmful gases must be assumed. Even though the pyrolysis gases of synthetic resin are oxidized faster than those of pitch binder – which is detected easily by the almost soot-free combustion – a quantitative combustion is only possible with Lambda values above 1.5.

A very gradual heating up in terms of thermal shock loading is practiced in Plant C. Within 8 hours, the lining surface is heated almost linearly up to 1000 °C. With this prolonged heat-up time, however, it must be assumed that carbon burn-off on the lining surface is unnecessarily promoted.

During BOF operation, the aim is to achieve the highest possible number of heats by making use of all available means. For example, the efficient use of scrap can have very positive effects here. Therefore, scrap sorting, preparation, and preheating as well as filling the charging boxes with small scrap items should be optimized. Similarly, correct charging, lance control, oxygen supply, blowing time, and flushing operations are necessary. Equally effective for a long campaign life are optimum use of the slag for protection, and special maintenance with suitable gunning mixes.

Further information about our Knowledge
Management Program is available under:

www.refra-academy.com



Refratechnik Steel GmbH
Schiessstrasse 58
40549 Düsseldorf
Germany
Phone +49 211 5858 0
Fax +49 211 5858 49
steel@refra.com
www.refra.com